



Looking after your new Nulook Windows and Doors

Your care and maintenance guide

Welcome to your new home. We hope you find it a great place to live.

Nulook wants to help make your home a great place to live, with windows and doors that provide you with a perfect blend of form and functionality.

They look good, and work well, providing you with effortless opening and closing, ventilation as well as a lovely sense of light and space.

Your Nulook windows and doors are made to last. Wind, rain and sunlight will, however, take their toll over the years. To ensure your aluminium joinery continues to look great and work well into the future, you'll need to do some light cleaning and maintenance from time to time.

The harsher the environment (eg. near the sea or in high wind and rain zones), the more regular that maintenance will need to be.

This Guide provides you with useful tips around cleaning and maintenance. It's not designed to be a detailed Maintenance Manual or as a Warranty. It is recommended that the homeowner refer to the supplier care and maintenance guide for relevant information on the hardware, powder coat finish and performance of the glass installed in your home.

We strongly recommend that you access more detailed information around care and maintenance from relevant industry groups and suppliers.

To help you source this information, we've provided a checklist below.

www.wanz.co.nz

www.ganz.co.nz

www.assaabloy.co.nz

www.doric.com.au

www.allegion.co.nz

www.interpon.co.nz

www.metroglasstech.co.nz

www.viridianglass.co.nz



If major repairs or maintenance is required (either to the framing or the glass), or you have queries around your product warranty, please contact your nearest Nulook fabricator on **0508 800 755** or email info@nulook.co.nz

Tips to keep your windows and doors operating smoothly.

Your Nulook windows and doors are designed to open and close smoothly and without fuss. You can ensure this smooth operation continues for years to come simply by following these easy steps.

- Make sure you run your vacuum along the sills and tracks regularly to remove any dirt and grime. It's also a good idea to do this before you wash your windows and doors.
- Check that the drainage holes are clear (you'll find these holes outside the window or door in the bottom of the frame). You can clear away any dirt and obstructions with a small, soft bottle brush. Please note that if your window is "stacked", there may be small drainage holes between units or behind the track.
- It's important that all of the moving parts in your hardware components, tracks and rollers (if accessible) are regularly lubricated. We'd advise to do this once every two months. You can do this with a Teflon-based lubricant. If, however, your home is near the sea or exposed to salt air, we recommend that you lubricate the components once every four weeks.
- Check the weatherstripping around your window and door panels to make sure it is sealing evenly. If it looks like there are some gaps, we recommend that you contact your local Nulook fabricator on 0508 800 755.
- The seals and rubbers around the glass will need to be replaced from time to time depending on the environment. As a general rule, they should last for ten years or more. Replacing them is quite straightforward and can be done easily by a window/door maintenance service company.
- You may need to adjust your sliding door rollers to achieve proper height clearances. Most door rollers can be adjusted by using a screwdriver – there are access holes at both ends of the bottom of the sliding panel. When you're adjusting the roller, please ensure you lever the panel up so that there isn't any weight on the roller. When you've made roller adjustments, you may need to adjust the lock strike placement slightly, as follows.

Sliding Door (Strike Plate Adjustment)

You can adjust the strike plate by following these simple steps. They relate to the surface mounted sliding door lock and the strike plate: (Picture A)

- Firstly, check the lock is operating correctly.
- Difficulty in operating may result from the anti-slam pin not being fully depressed while the door is in the closed position.
- To correct, open and loosen the strike plate retaining the screws (B) by one turn.
- Carefully loosen the anti-rattle screw (C) until the strike plate is no longer free to move.
- Note: care must be taken making these adjustments as excessive force may bend the strike plate.
- Check the lock operation and repeat if necessary.
- Rescrew the strike plate.

Sliding Door (Roller Adjustment)

Insert a screwdriver as shown and engage screw to adjust the roller height. (Picture B)

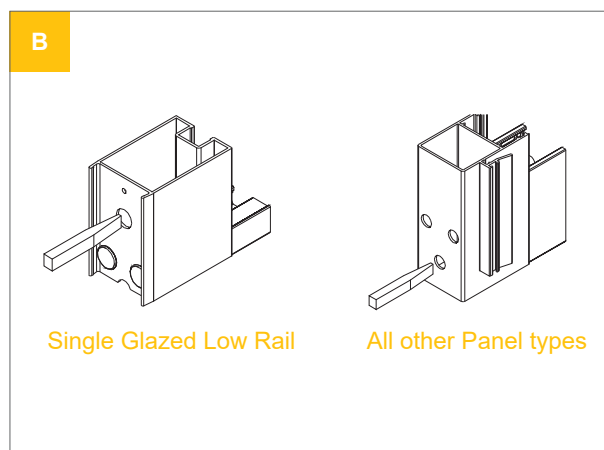
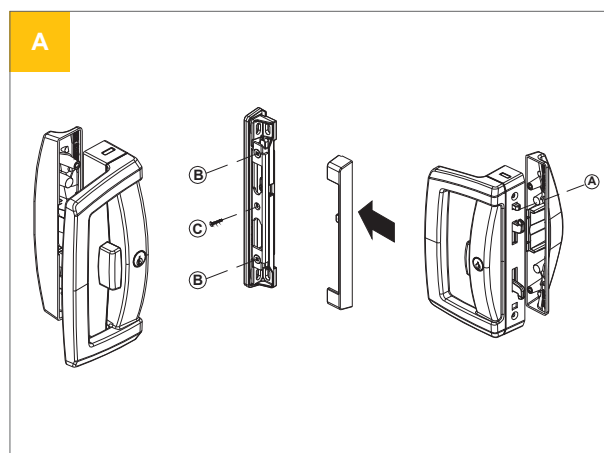



Good looks that last, with just a little bit of help from you.

Washing glass

Washing and drying the glass on your windows and doors every three to six months will keep those views looking crisp and clear.

Here are some simple steps to follow.

1. First, you'll need to loosen dirt and debris. Do this by soaking the glass surface with either warm water mixed with a mild soap detergent (such as dishwashing liquid) or a recognised glass cleaner.
2. After washing, rinse the glass with clean water and then dry it off with a clean, grit-free squeegee, cloth or paper towel.
3. Make sure that any water or cleaning solution residue is dried off the window gaskets, sealants and frames. This will prevent water spots.
4. Clean double glazed or laminated glass following the same steps as shown above for normal glass. Please make sure, however, that no solvent comes into contact with the edge laminate interlayer or the unit sealant.
5. Check that the frame drainage isn't blocked.
6. Be extra careful when you're washing reflective or Low E coated surfaces. Make sure you always follow the manufacturer's instructions. If you're unsure about these, refer to the second page for glass supplier website details. It is recommended that you read the information provided on glass quality from the supplier.

Cleaning tinted and reflective glass

Avoid cleaning tinted or reflective glass surfaces in direct sunlight (so early in the morning, late in the afternoon or even early evening are the best times).

Taking care of powder coated frames

You can wash the powder coated frames of your windows or doors with warm water and a mild detergent. **DO NOT** use a strong solvent cleaner as this will be harmful to the powder coating.

- If the powder coated surface has lost its gloss or is looking chalky, apply a high quality cream polish to the frame using a soft cloth. We strongly recommend that you read the manufacturer's instructions before you do this (contact your nearest Nulook fabricator if you're not sure). Avoid polishes that contain cutting compounds, again a Nulook fabricator in your region will be able to advise you on the best products to use.
- Powder coating on frames that are in sheltered areas will be more at risk of coating degradation. This is because wind-blown salt, grit and grime will stick to the surface. We recommend, therefore, that you check and clean window and door frames in these areas on a more regular basis





Maintenance of anodised joinery frames

Anodising provides a tough, hard-wearing finish to your aluminium window and door frames. Some deterioration could occur over the years. This can be caused by grime building up on the frame, which in turn will trap moisture that can etch away at the anodised surface.

Regular cleaning will prevent build-up of grime and keep your joinery looking great for years. It's much like cleaning your car.

- Wash the aluminium with warm water and a suitable wetting agent or mild soap detergent. Use a sponge or a cloth. If you need to loosen dirt or grime, you can use a fine brush, but avoid using anything stiffer or more abrasive as you could end up damaging the surface. DO NOT use acid or alkali cleaners. These will damage the surface and could even discolour the joinery.
- You can clean away greasy deposits or really hard to remove grime by using a soft cloth dipped in white spirit, turpentine, kerosene or a mild liquid scourer. Make sure however that these solvents don't come into contact with any other parts of the window or door (including the rubber seal around the glass), as they will damage them. Remember to use a rag to dry off the joinery immediately after cleaning.
- You can provide extra protection for your anodised joinery by cleaning it with a good quality car wax after each wash. This will also lift the appearance of your joinery and keep it looking better, longer.

Important Point

After cleaning, rinse anodised joinery thoroughly with lots of clean water and then dry the glass to prevent water spots.

How often should anodised joinery be cleaned?

- Rural environments – every six months.
- Urban environments – every three months.
- Industrial and marine environments (or places that are exposed to a lot of salt and sulphur in the air) – every six months, as well as a cold water wash every month.





Care and maintenance of your window and door hardware.

General periodic care and maintenance is required on all hardware to ensure they continue to function correctly and maintain their appearance.

It's important that you clean any harmful residue (such as salt sea spray) from the surface of your hardware to keep it looking good for years to come.

Before doing any cleaning or maintenance, you must establish exactly what hardware has been installed on your external windows and doors. It may be that the hardware used has come from more than one supplier. As a result, it may be constructed differently or made of different materials.

Cleaning

Powder Coated Hardware

1. Remove loose dirt with a wet sponge.
2. Using a soft brush or cloth and soap or mild domestic detergent in warm water, clean any dust, salt or other deposits from the hardware surface.
3. Thoroughly rinse with fresh water after cleaning to remove any remaining soap/detergent.

If you want to repair any weathered, blemished or scratched powder coat areas, please contact your local Nulook fabricator.

Plated Hardware

Plated hardware requires special care. It's important that you remember the following points.

- Clean with a soft damp cloth or dry duster.
- Do NOT use abrasive cleaners, scourers or rough cloths.
- Do NOT use detergent or chemical cleaners
- When cleaning windows, don't use spray window cleaners as there is a risk that some of the spray will land on the plated hardware.
- If you are painting, varnishing or plastering, remember to protect or cover the plated surfaces.





Stainless Steel Hardware

- Clean regularly using detergent and warm water. Rinse with fresh water and thoroughly dry the surface.
- Clean away any stains and discolouration with citric or nitric acid-based cleaners or a mild abrasive detergent. Rinse with fresh water and dry.
- Do NOT clean with wire wool or wire brushes as these will leave iron deposits that will rust.
- Do NOT allow salt deposits to build up on stainless steel product.
- Stainless steel is not stain proof - tea staining and other marks may appear.

NOTE: Avoid mechanical abrasives, hard water (deposits) and cleaners containing chlorides as they break down stainless steel's passivity layer and allows corrosion to occur.

Maintenance

Lubrication for Mechanisms

Mechanisms include friction slays, hinges, cylinders, mortise locks, rollers and fasteners. You can keep these mechanisms in good working order through regular cleaning and lubrication. We recommend a Teflon-based lubricate or please refer to the manufacturer's care instructions.

A soft bristle brush can be used on exposed parts. Apply Teflon-based lubricate to the moving parts – you don't need to use very much. This will limit corrosion of the exposed metals.

Electrical Entrance Systems

Do not let the product get wet.

- Keep clear of debris and general dirt.
- Wipe the keypads or swipe the device with a clean damp cloth.
- Do NOT use solvents.
- Replacement batteries will be required.

NOTE: If you have any doubt or are unsure about the cleaning method it is recommended that you contact your nearest Nulook fabricator and hardware manufacturer.

Sash Handles

When opening and closing your sash or awning windows, make sure that the lever is fully in the correct position as shown in the picture below before you push the window open or pull it closed. That way, you'll avoid any damage caused by the hardware and rubber hitting the joinery.

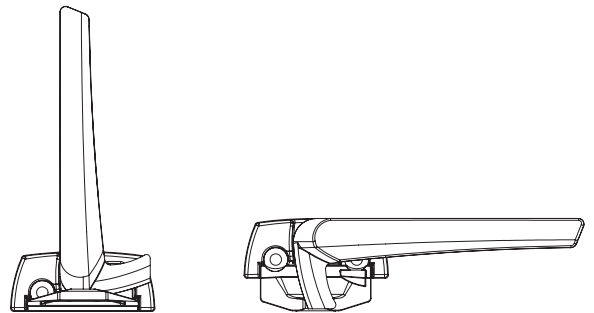

Nulook Northland
19 Clark Road, Kamo
WHANGAREI 0112
Tel: 09-435 0038 Fax: 09-435 0069
Email: sales@nulooknorthland.co.nz

Nulook North
62 Forge Road, Silverdale
AUCKLAND 0932
Tel: 09-426 7042 Fax: 09-426 7041
Freephone: 0508 424 8472
Email: windows@nulooknorth.nz

Nulook North Harbour
158 Bush Road, Albany
AUCKLAND 0632
Tel: 09-448 1575
Email: sales@nulooknorthharbour.co.nz

Nulook Kumeu
12 Loft Place, Kumeu
AUCKLAND 0618
Tel: 09-412 8569 Fax: 09-412 7439
Email: stuart@nulookkumeu.co.nz

Nulook Henderson
16B Keeling Road, Henderson
AUCKLAND 0612
Tel: 09-837 3491 Fax: 09-837 3492
Email: hulme@xtra.co.nz

Nulook Central
262 Church Street, Onehunga
AUCKLAND 1061
Tel: 09-625 0001
Freephone: 0800 275 223
Email: andrew@nulookcentral.co.nz

Nulook East
Unit G, 154-160 Harris Road, East Tamaki,
AUCKLAND 2013
Tel: 09-272 8186 Fax: 09-273 9764
Email: nulooket@outlook.com

Nulook Windows 2000
52 Tidal Road, Mangere South
AUCKLAND 2022
Tel: 09-275 1575 Fax: 09-275 1586
Email: jill@win2000.co.nz

Nulook Huntly
402 Great South Road
HUNTLY 3700
Tel: 07-828 9091 Fax: 07-828 9036
Email: nulookhuntly@xtra.co.nz

Nulook Cambridge
18 Oliver Street
CAMBRIDGE 3434
Tel: 07-827 8367 Fax: 07-827 3897
Email: office@nulookcambridge.co.nz

Nulook Gateway - Tokoroa
11 Spence Street
TOKOROA 3420
Tel: 07-886 4297 Fax: 07-886 4298
Email: tokoroa@gatewayglass.co.nz

Nulook Waikato
25 Waihou Street
MATAMATA 3400
Tel: 07-888 4221 Fax: 07-888 5559
Email: darrin@nulookwaikato.co.nz

Nulook Te Aroha
28 Lawrance Avenue
TE AROHA 3320
Tel: 07-884 8389 Fax: 07-884 8379
Email: nulooktearoha@xtra.co.nz

Nulook Creations
66 Birch Avenue, Judea
TAURANGA 3110
Tel: 07-578 3917 Fax: 07-578 1429
Email: mark@nulookcreations.co.nz

Nulook Te Puke
210 Jellicoe Street
TE PUKE 3119
Tel: 07-573 7415 Fax: 07-573 7415
Email: nulooktepuke@clear.net.nz

Nulook Gateway - Rotorua
Corner of Te Ngae and Allen Mills Road,
ROTORUA 3010
Tel: 07-345 7816 Fax: 07-345 7816
Email: nulook.rotorua@gatewayglass.co.nz

Nulook New Plymouth
10 Cygnet Drive (off Corbett Rd), Bell Block
NEW PLYMOUTH 4373
Tel: 06-755 4176 Fax: 06-755 4179
Email: office.nulooknp@xtra.co.nz

Wairoa Building Supplies Ltd
159 Carroll Street
WAIROA 4108
Tel: 06-838 7332 Fax: 06-838 3303
Email: waibldsup@xtra.co.nz

Nulook CHB
16 Peel Street
WAIPUKURAU 4200
Tel: 06-858 8578 Fax: 06-858 8531
Email: nulook@xtra.co.nz

Nulook Levin
5 Totara Street
LEVIN 5510
Tel: 06-368 3523 Fax: 06-368 4823
Email: enquiries@nulooklevin.nz

Nulook Wanganui
4 Pacific Place, Gonville
WANGANUI 4500
Tel: 06-345 2375 Fax: 06-345 6041
Email: nulook.wanganui@xtra.co.nz

Nulook Kapiti
131 Makarini St
PARAPARAUMU 5032
Tel: 04-298 7091 Fax: 04-298 7715
Email: nulook-kapiti@xtra.co.nz

Capital Nulook
53 Montgomery Crescent, Clouston Park
UPPER HUTT 5018
Tel: 04-526 9933 Fax: 04-526 7856
Email: cwad@ihug.co.nz

Nulook Tasman Bay
20a Old Wharf Road
MOTUEKA 7120
Tel: 03-528 9057 Fax: 03-528 9051
Email: aaron@nulooktasmanbay.co.nz

Nulook Solutions - Nelson
16 Nayland Road, Stoke
NELSON 7011
Tel: 03-538 0100 Fax: 03-538 0609
Email: stephen.scott@nulooksolutions.co.nz

Nulook Blenheim
41 Houldsworth Street
BLENHEIM 7201
Tel: 03-578 3049 Fax: 03-578 0161
Email: rick.may@blenheimitn.co.nz

Nulook Sotherans
Cnr Leonard and Herbert Streets
GREYMOUTH 7805
Tel: 03-768 7643 Fax: 03-768 7630
Email: sotherans@xtra.co.nz

Bates Aluminium Ltd
101 Shortland Street, Wainoni
CHRISTCHURCH 8061
Tel: 03-388 8027 Fax: 03-388 6240
Email: enquires@batesaluminium.co.nz

Nulook Canterbury
11 Henry Street, Waltham
CHRISTCHURCH 8011
Tel: 03-389 6466 Fax: 03-389 6076
Email: mark.fisher@nulookcanterbury.co.nz

Nulook Solutions - Christchurch
14 Dakota Crescent, Wigram
CHRISTCHURCH 8042
Tel: 03-343 8866
Email: stephen.scott@nulooksolutions.co.nz

Raylight Aluminium Ltd
20 Pilkington Way, Wigram
CHRISTCHURCH 8024
Tel: 03-366 5637 Fax: 03-366 1790
Freephone: 0800 366 567
Email: raylight@xtra.co.nz

Nulook Morse
67 Church Street
TIMARU 7910
Tel: 03-688 3062 Fax: 03-688 3061
Email: morse-aluminium@xtra.co.nz

Nulook Oamaru
14 Humber Street
OAMARU 9400
Tel: 03-434 7161 Fax: 03-434 7161
Email: office@nulookoamaru.co.nz

Nulook Morlite
307 Kaikorai Valley Road, Bradford
DUNEDIN 9011
Tel: 03-453 5980 Fax: 03-453 5369
Email: sales@morlite.co.nz

Nulook Abell
21 Lyne Street
GORE 9710
Tel: 03-208 4737 Fax: 03-208 9747
Email: abell.alum@gmail.com

Nulook North End Joinery
59 Essex Street
BALCLUTHA 9230
Tel: 03-418 1390 Fax: 03-418 1393
Email: nej@ispnz.co.nz

Nulook Wanaka
7 Gordon Road
WANAKA 9305
Tel: 03-443 1390 Fax: 03-443 1392
Email: wanaka.nulook@xtra.co.nz

Nulook Otautau Joinery
90 King Street
OTAUTAU 9610
Tel: 03-225 8381 Fax: 03-225 8953
Email: otautaujoinery@paradise.net.nz

Nulook Southland
1 Kinloch Street, Prestonville,
INVERCARGILL 9810
Tel: 03-215 9068 Fax: 03-215 9531
Email: sam@nulooksouthland.co.nz

